

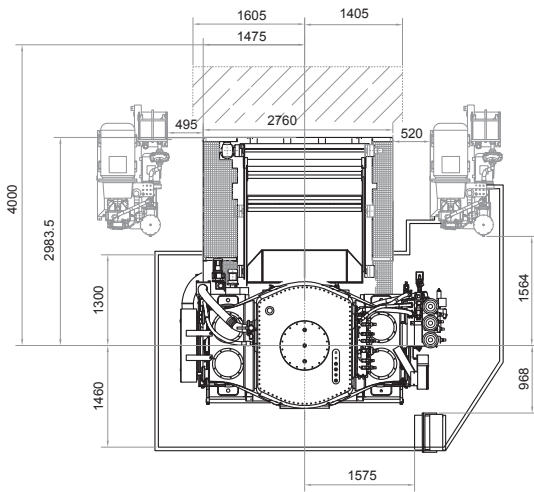

PHC3500

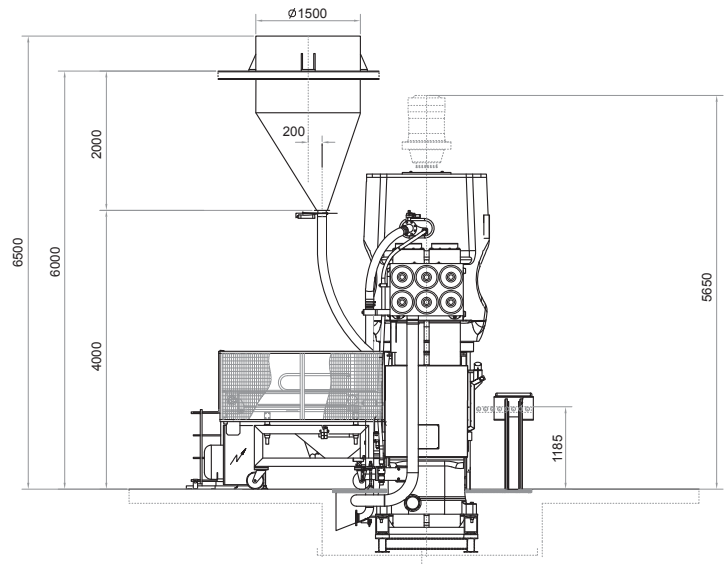

**SACMI**  
Ceramics, better.

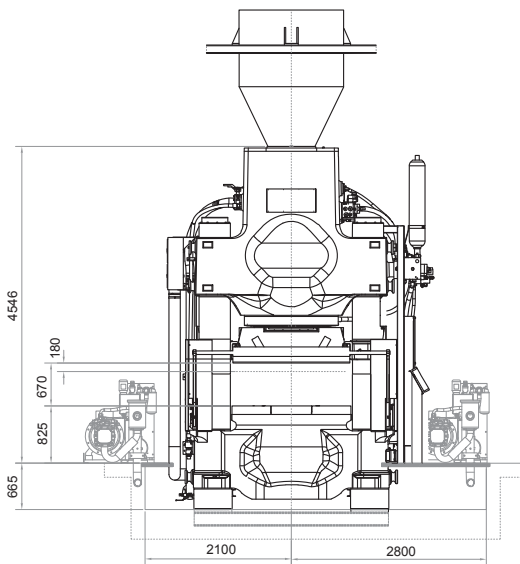

# PHC3500

## TECHNICAL DATA - DATI TECNICI - DATOS TÉCNICOS - 技术数据

Max pressing force Forza di pressatura Fuerza máxima de prensado 最大压制力	kN	35,000	Optional die heating Riscaldamento stampi opzionale Calentamiento de los moldes optional 选购项模具加热装置	kW	50
Clearance between columns Luce libera orizzontale Luz libre entre las columnas 立柱间距	mm	1,750	Oil quantity for hydraulic system Quantità di olio per impianto oleodinamico Cantidad de aceite para circuito hidráulico 液压系统油量	Lt	1,200
Max plunger stroke Corsa traversa mobile Máxima carrera travesano 冲头最大行程	mm	180	Number of cycles up to Numero cicli fino a Número de ciclos hasta 工作循环次数		19/min
Effective ejector stroke Corsa utile estrattore Carrera útil del extractor 脱模装置有效行程	mm	74	Oil cooling water (20°C) Acqua raffreddamento (20°C) Agua enfriamiento aceite (20°C) 液压油冷却水量 (20°C)	lt	50/min
Maximum ejector force Forza max estrattore SPE Fuerza máxima del extractor SPE装置最大顶出力	kN	150	Total net weight Peso totale corpo pressa Peso neto total 压机机身总重量	ton	64
Installed power in motors Potenza elettrica installata motori (50 Hz) Potencia eléctrica motores instalada 马达装机功率	kW	98			